



US 20180366059A1

(19) **United States**

(12) **Patent Application Publication**

Lee et al.

(10) **Pub. No.: US 2018/0366059 A1**

(43) **Pub. Date: Dec. 20, 2018**

(54) **FLEXIBLE DISPLAY DEVICE AND METHOD FOR FABRICATING THE SAME**

G09G 5/00 (2006.01)

H01L 51/00 (2006.01)

G06F 3/038 (2013.01)

(71) Applicant: **LG Display Co., Ltd.**, Seoul (KR)

(52) **U.S. Cl.**

CPC *G09G 3/3225* (2013.01); *H01L 27/3267*

(2013.01); *G09G 5/00* (2013.01); *H01L*

51/003 (2013.01); *H01L 51/0097* (2013.01);

Y02E 10/549 (2013.01); *G06F 3/038*

(2013.01); *G09G 2380/02* (2013.01); *G09G*

2310/0283 (2013.01); *H01L 2251/5338*

(2013.01); *H01L 2251/566* (2013.01); *G09G*

2310/0221 (2013.01)

(72) Inventors: **Chanwoo Lee**, Gyeonggi-do (KR);
SungJoon Min, Gyeonggi-do (KR);
KwonHyung Lee, Seoul (KR);
Yeonjun Oh, Gyeonggi-do (KR)

(73) Assignee: **LG Display Co., Ltd.**, Seoul (KR)

(21) Appl. No.: **16/110,943**

(22) Filed: **Aug. 23, 2018**

Related U.S. Application Data

(63) Continuation of application No. 14/983,876, filed on Dec. 30, 2015, now Pat. No. 10,089,922.

Foreign Application Priority Data

Jul. 31, 2015 (KR) 10-2015-0109144

Publication Classification

(51) **Int. Cl.**

G09G 3/3225 (2016.01)

H01L 27/32 (2006.01)

(57)

ABSTRACT

A flexible display device includes a flexible substrate includes first and second portions that overlap each other, and a bending portion connecting the first portion with the second portion. A first display having a first organic light emitting diode is on the first portion, the first display configured to display an image in a first direction, and a second display having a second organic light emitting diode is on the second portion, the second display configured to display an image in a second direction. A gate driver is on the bending portion, and is configured to drive gate lines in each of the first and second displays.

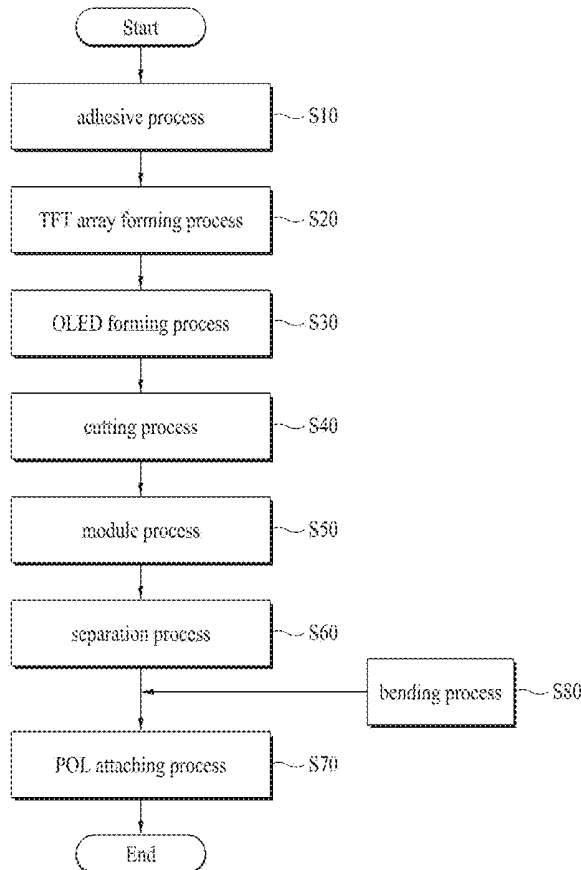

FIG. 1

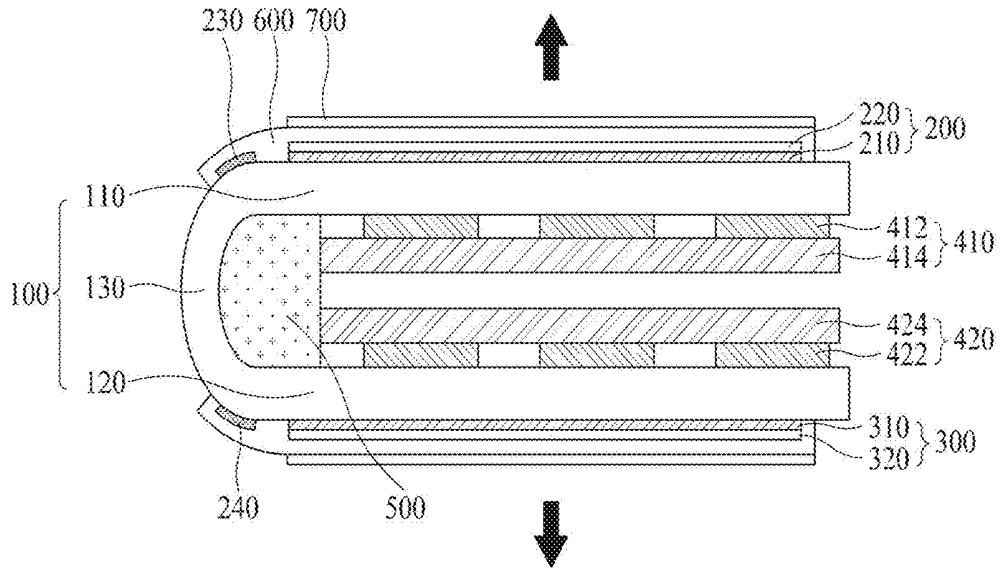

FIG. 2

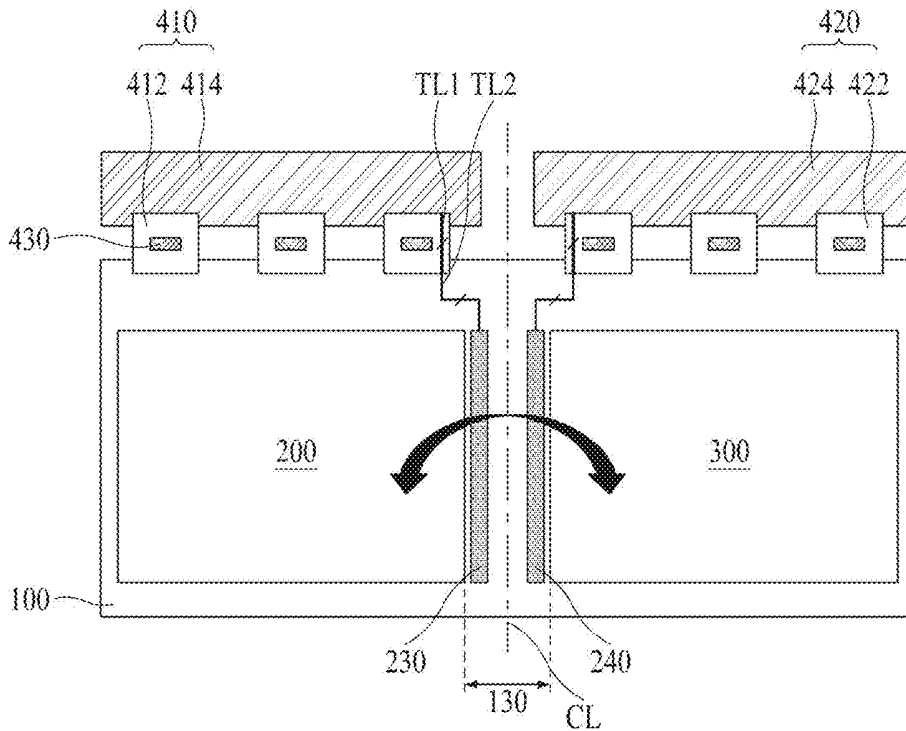

FIG. 3A

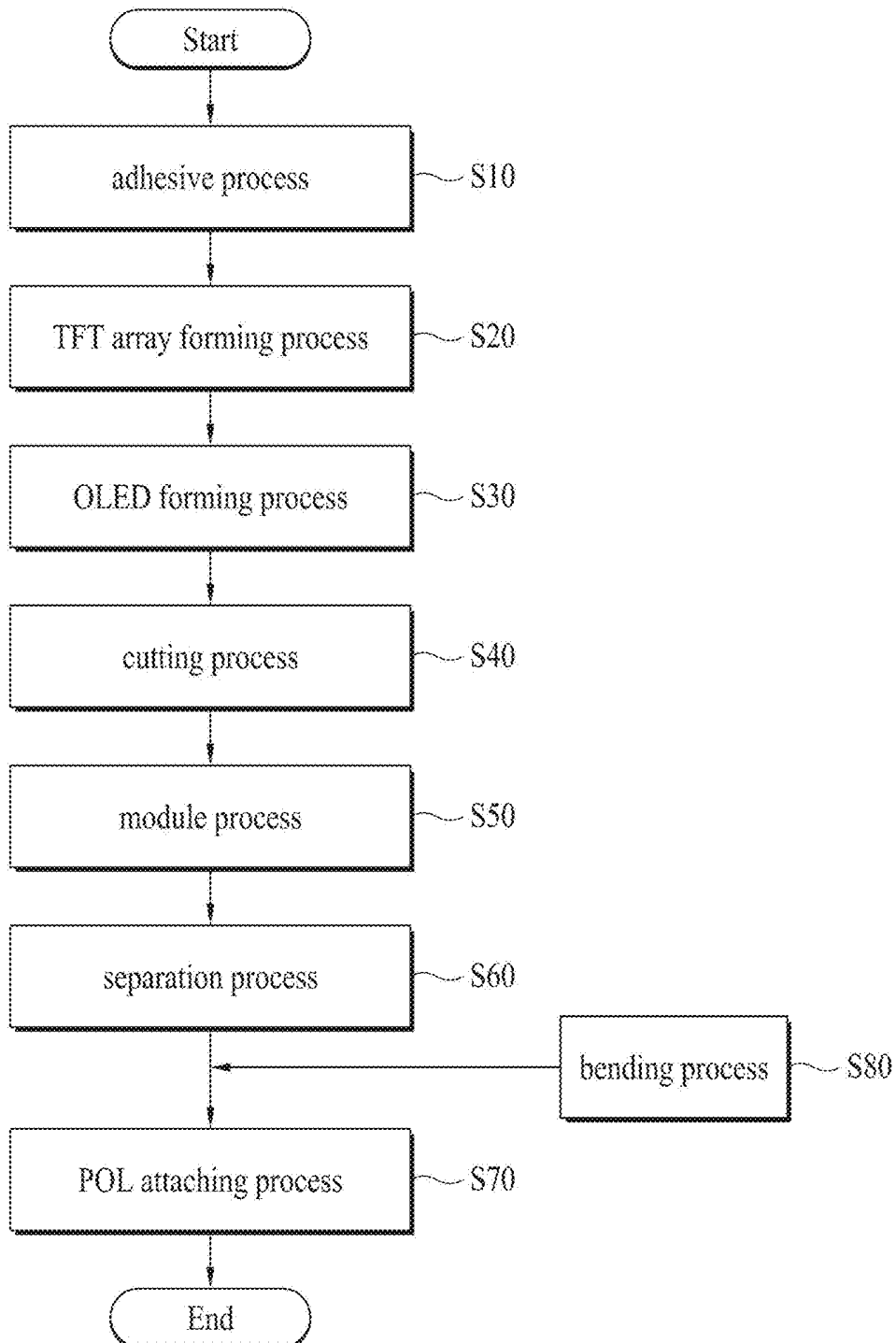

FIG. 3B

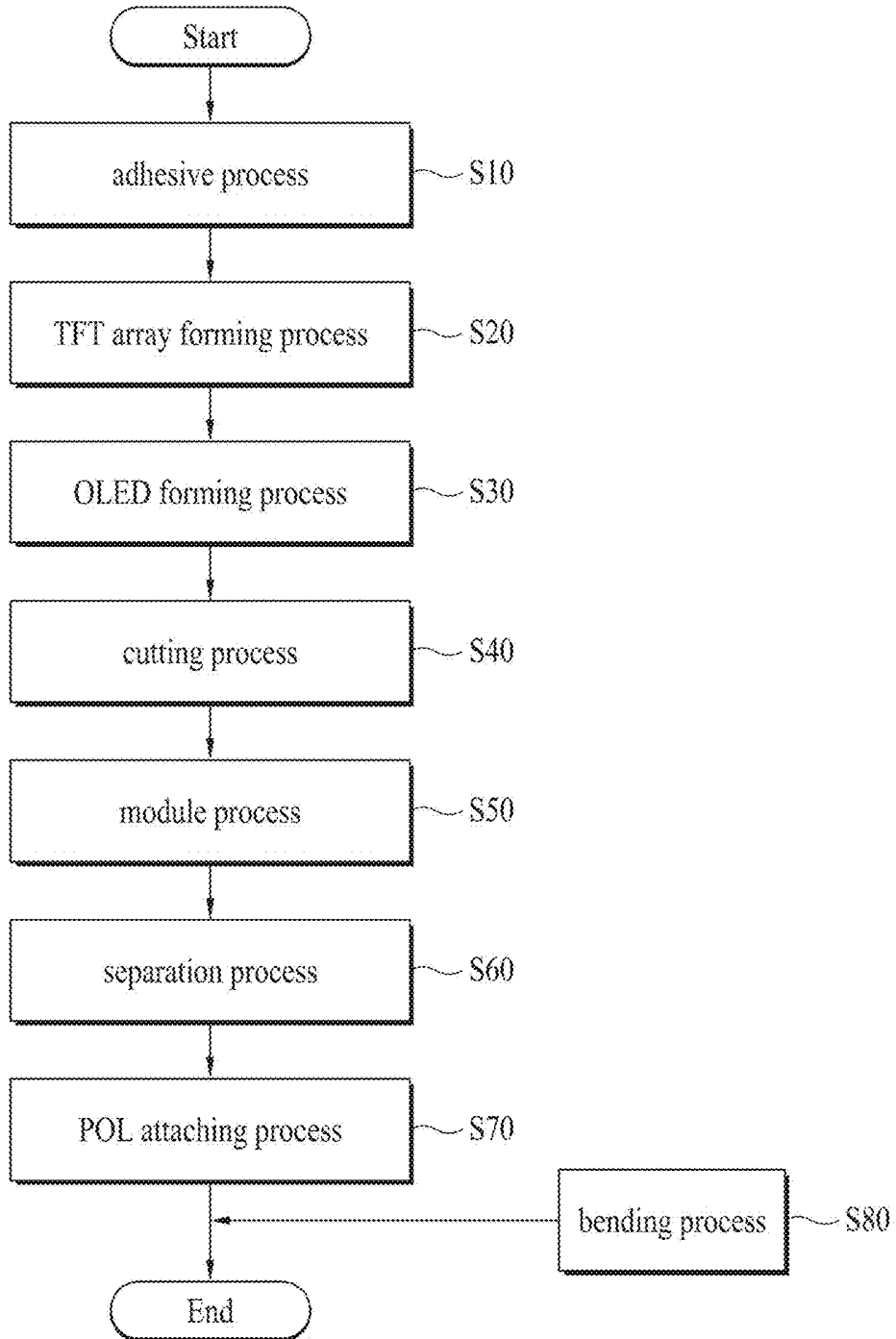

FIG. 4

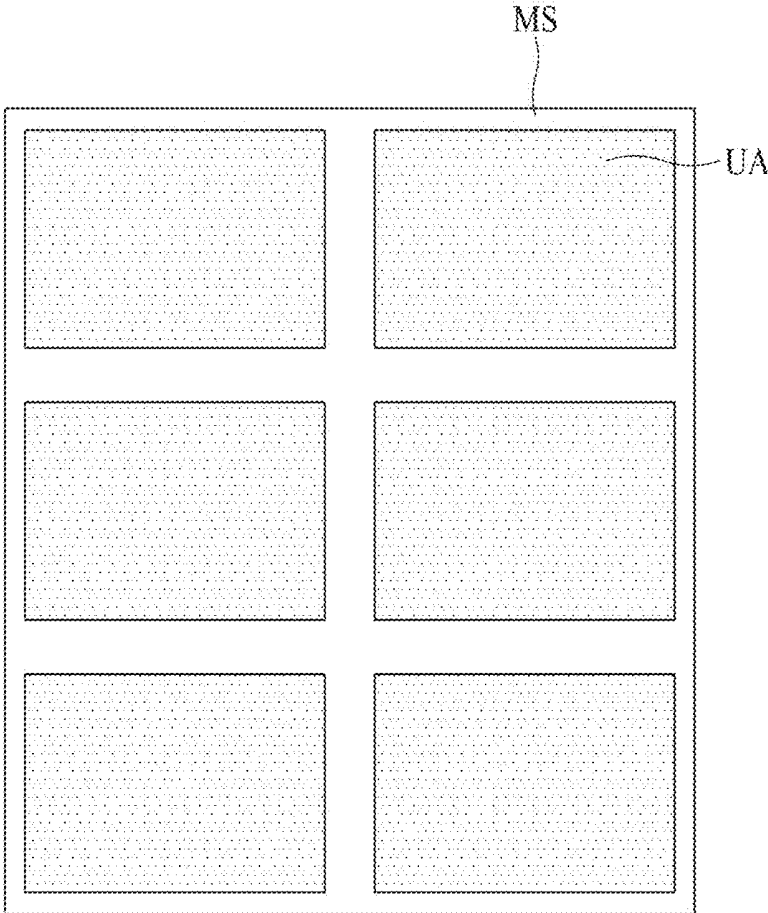

FIG. 5A

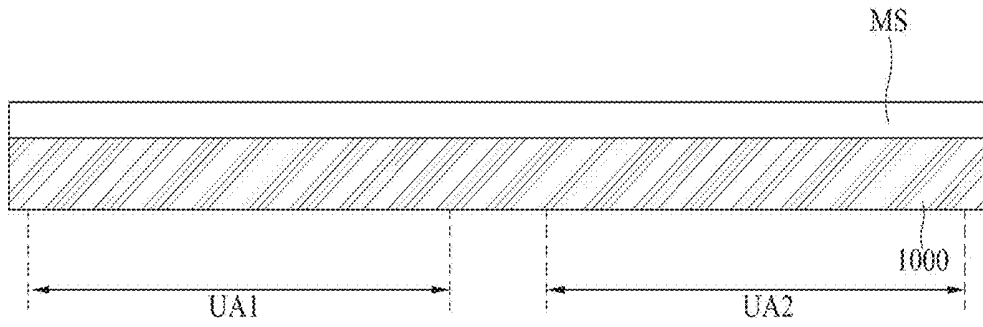

FIG. 5B

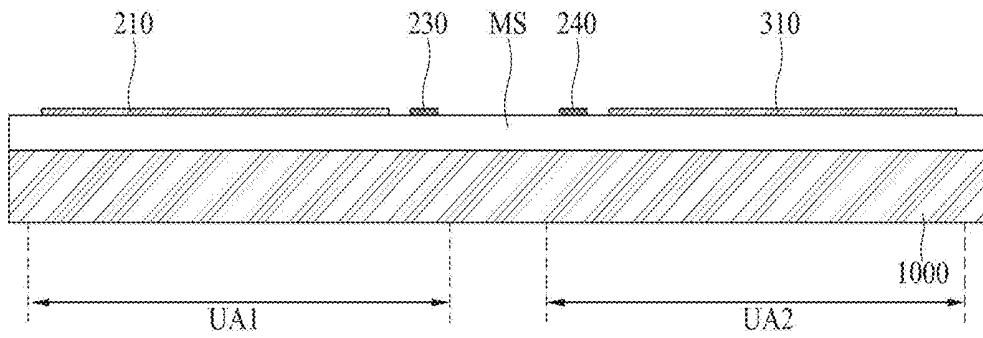

FIG. 5C

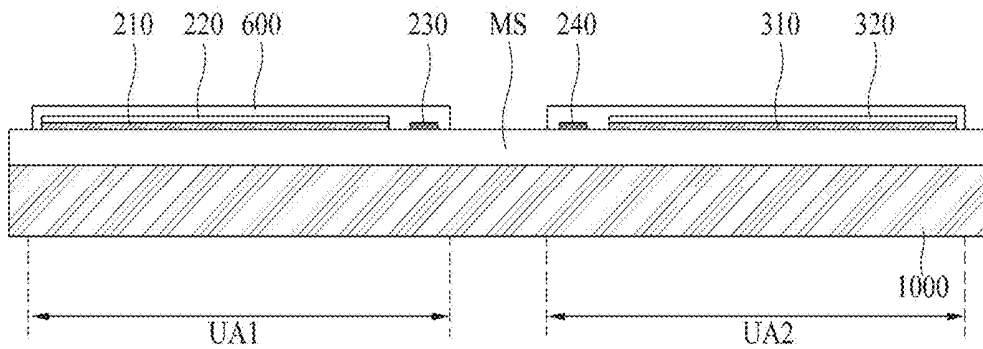

FIG. 5D

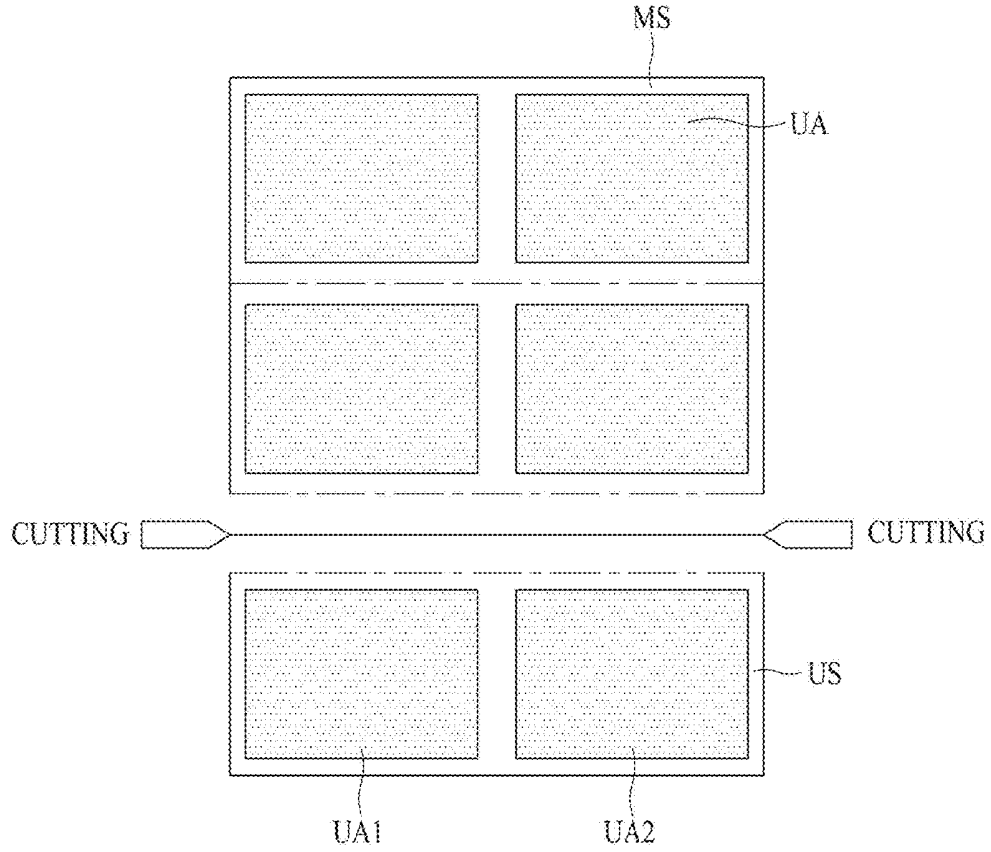

FIG. 5E

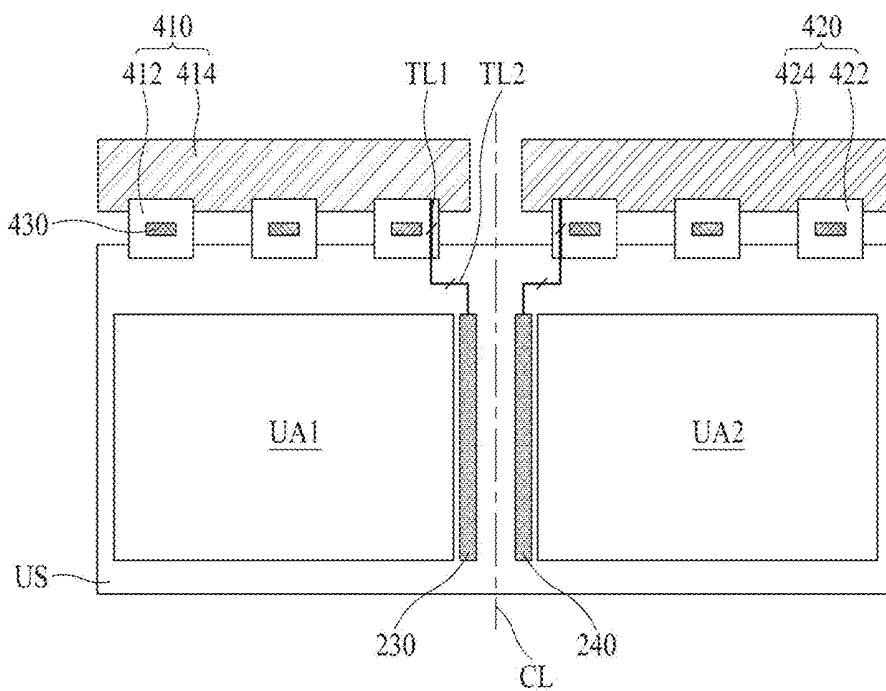

FIG. 5F

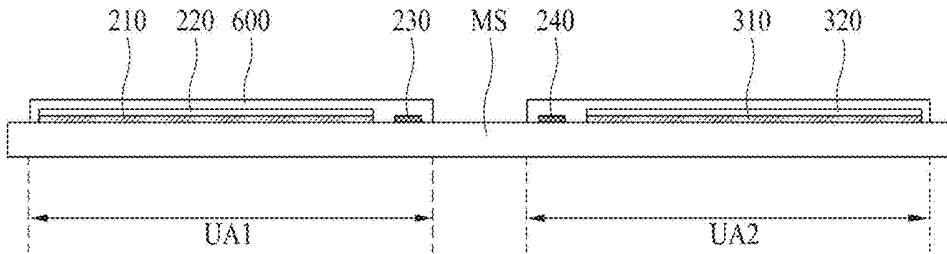

FIG. 5G

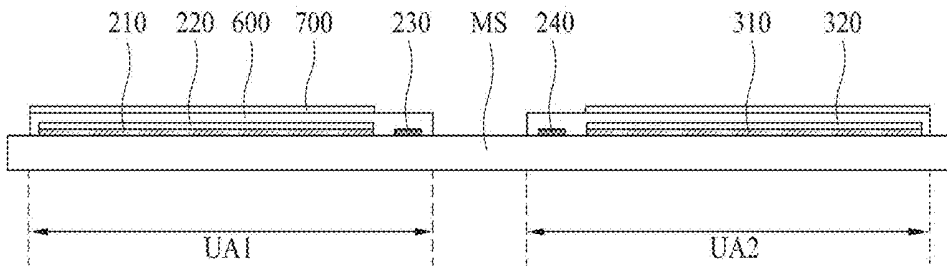

FIG. 5H

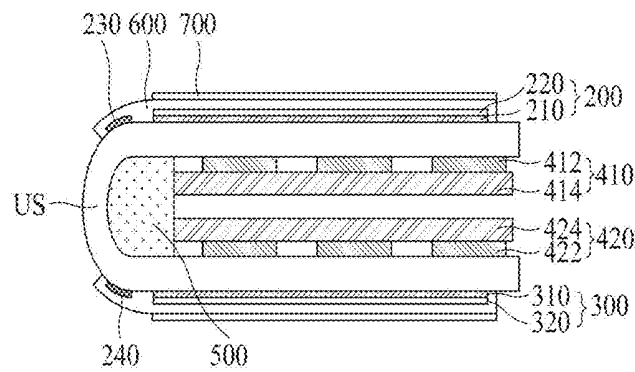

FIG. 6

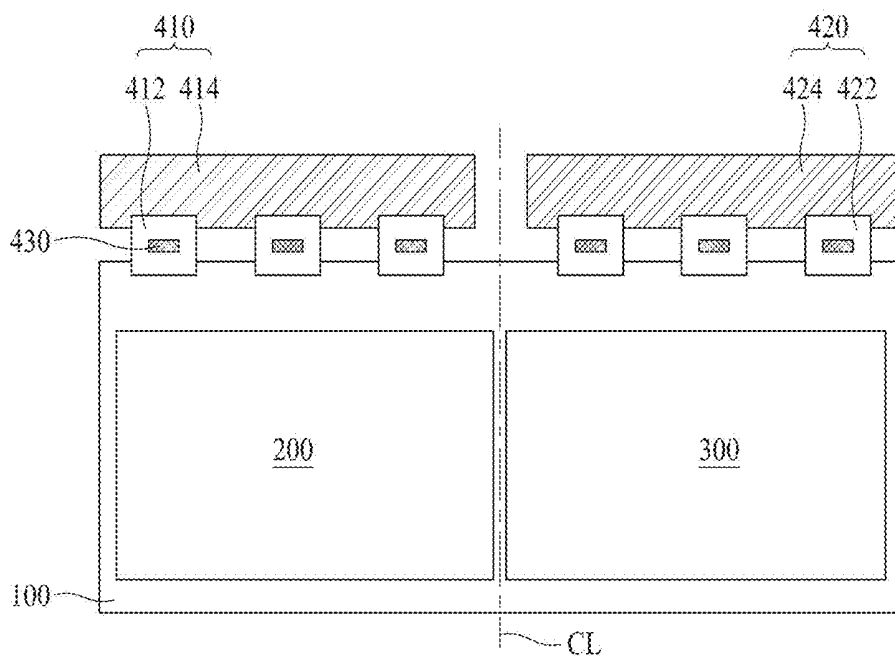

FIG. 7

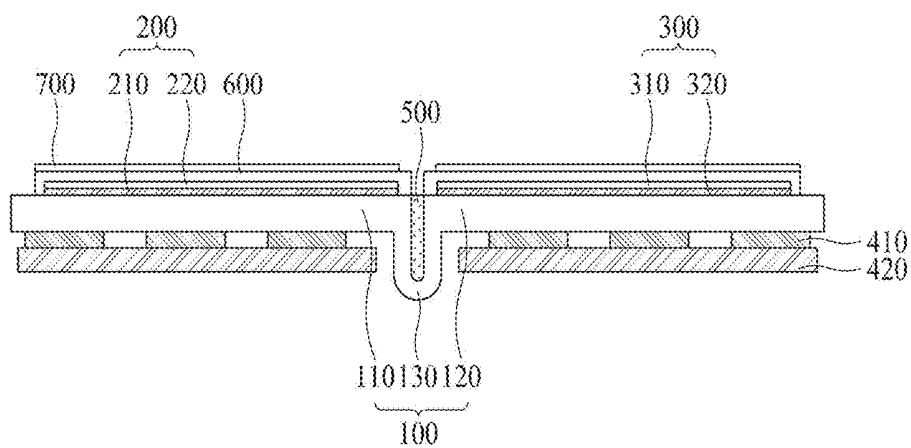

FIG. 8

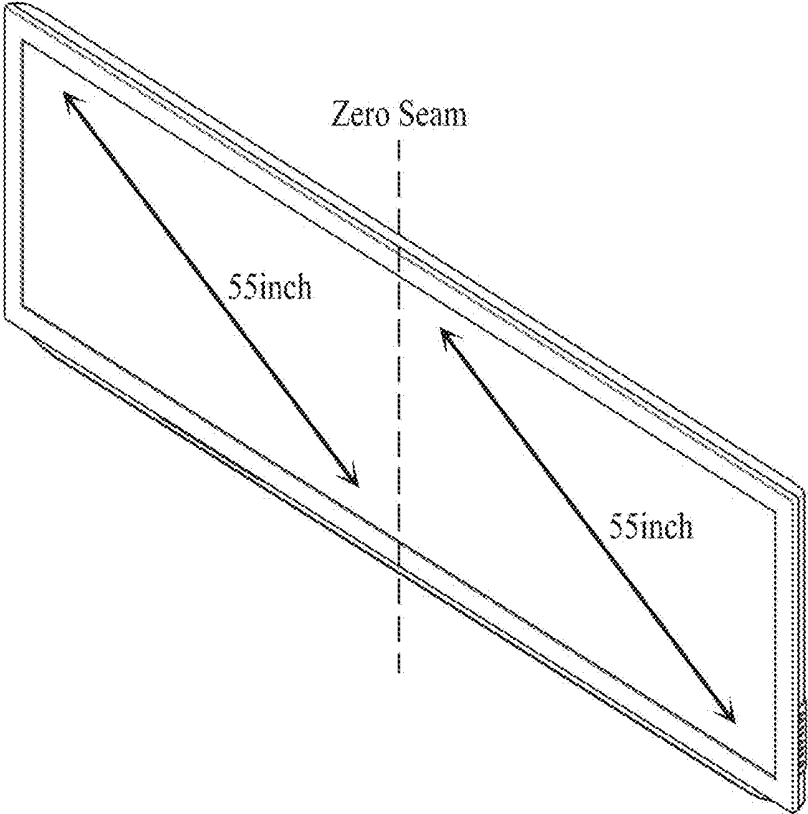

FIG. 9A

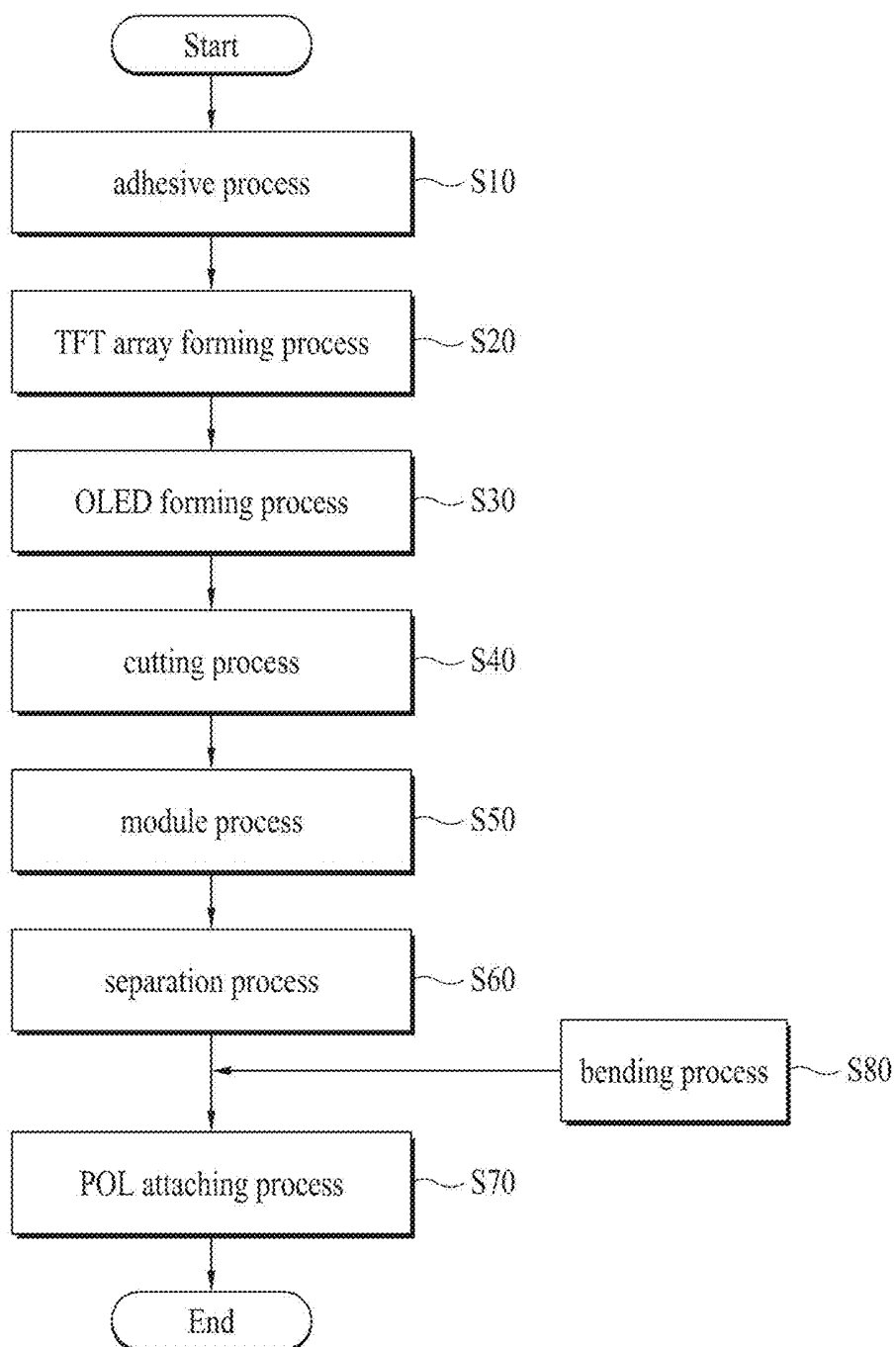

FIG. 9B

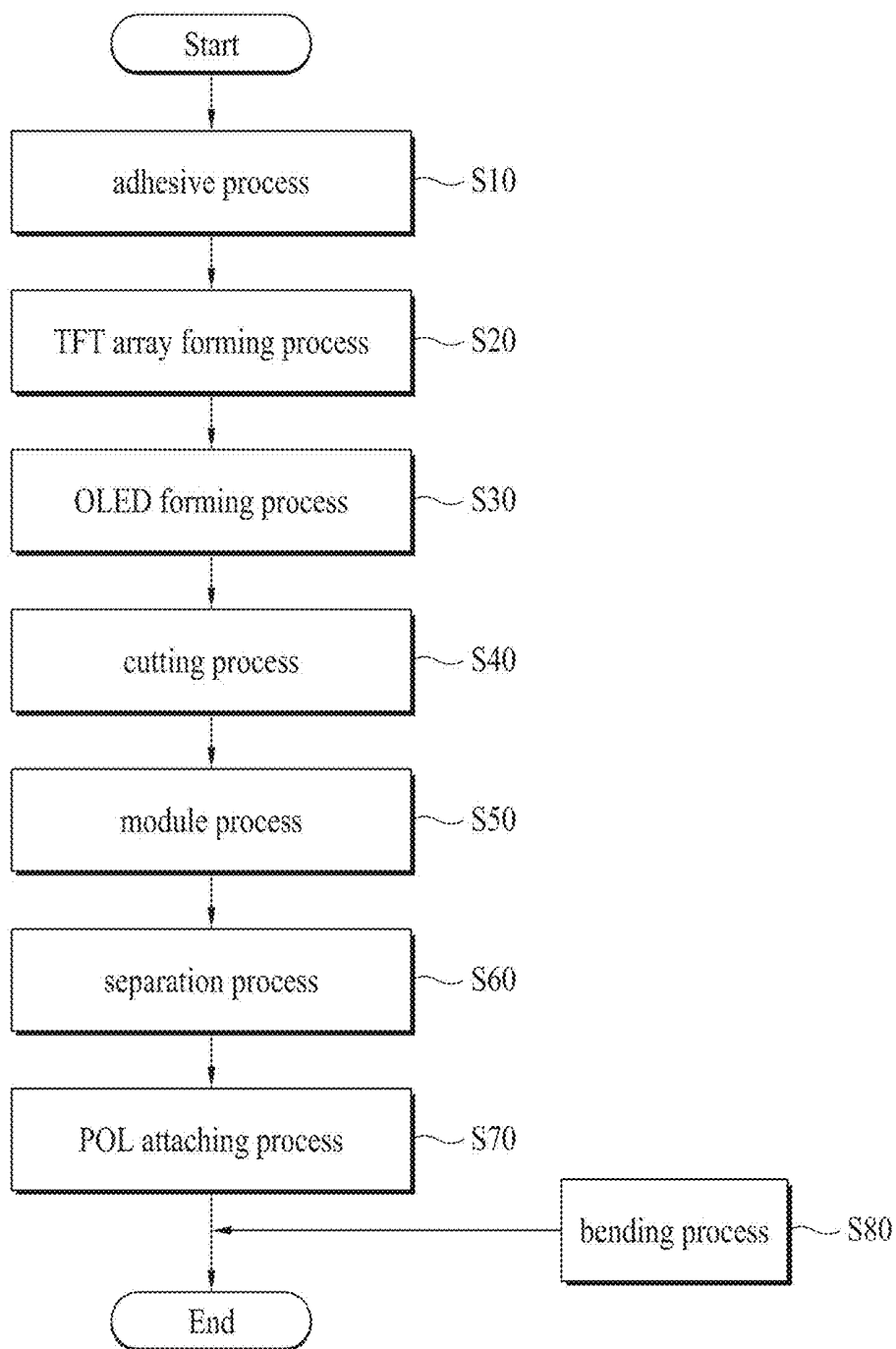

FIG. 10A

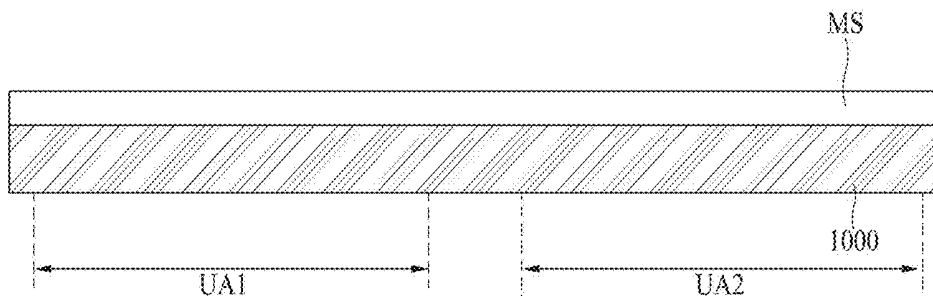

FIG. 10B

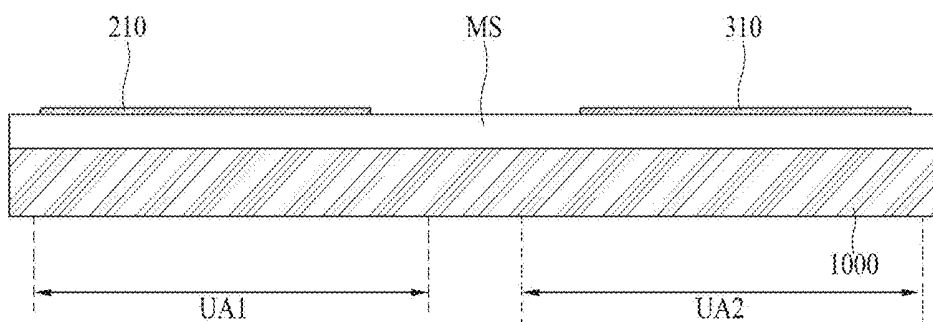

FIG. 10C

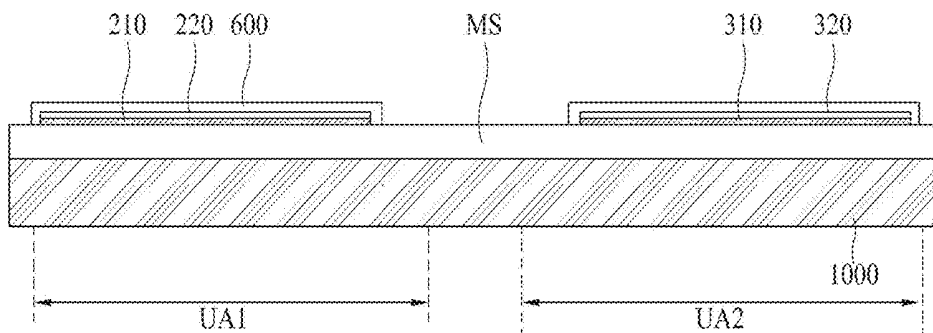

FIG. 10D

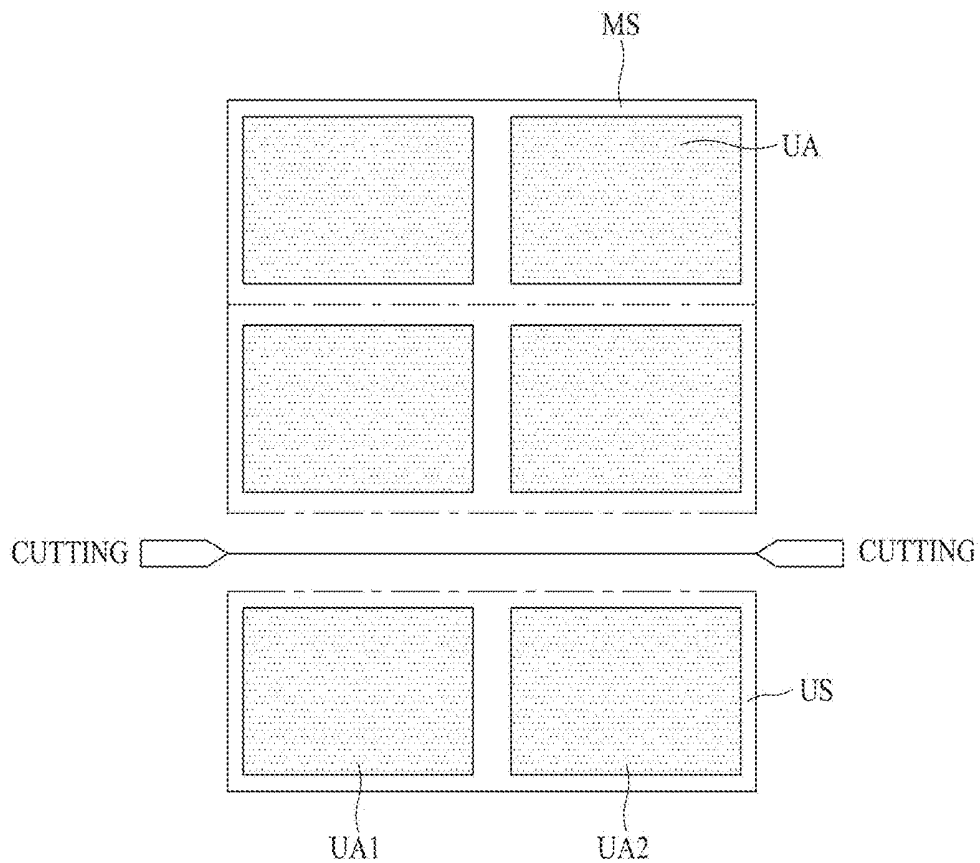

FIG. 10E

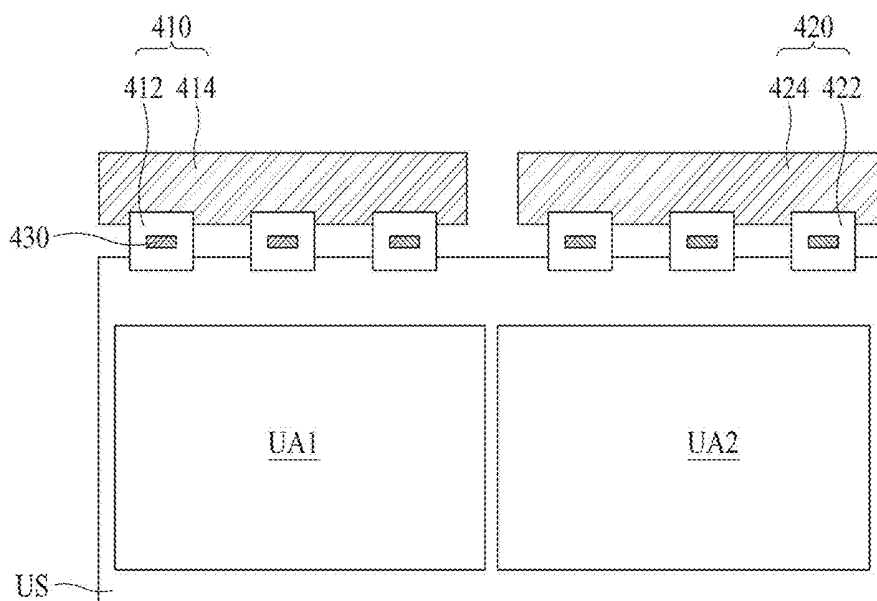

FIG. 10F

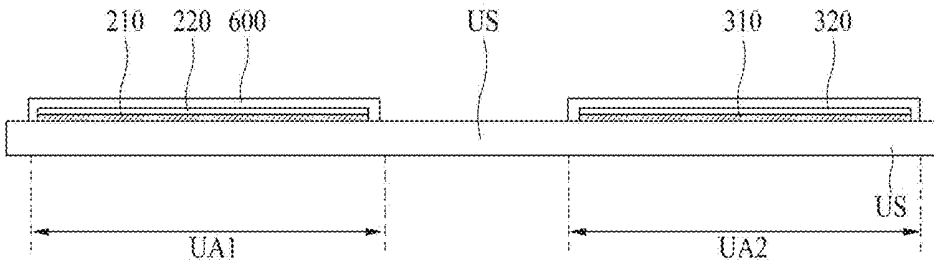

FIG. 10G

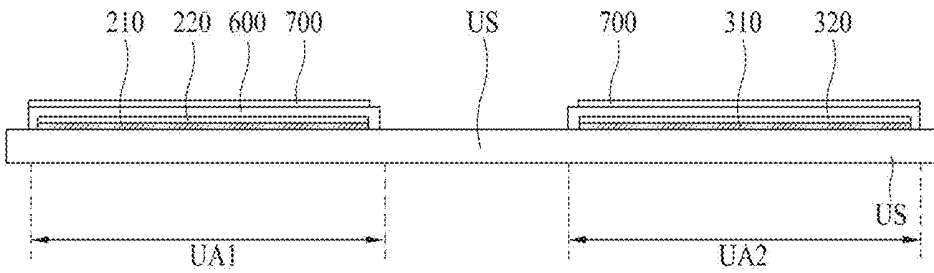

FIG. 10H

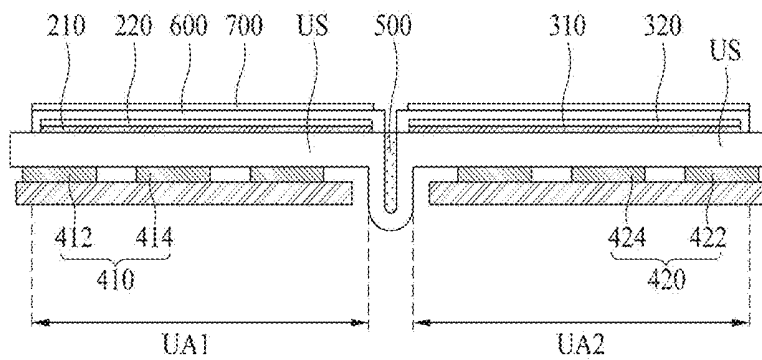
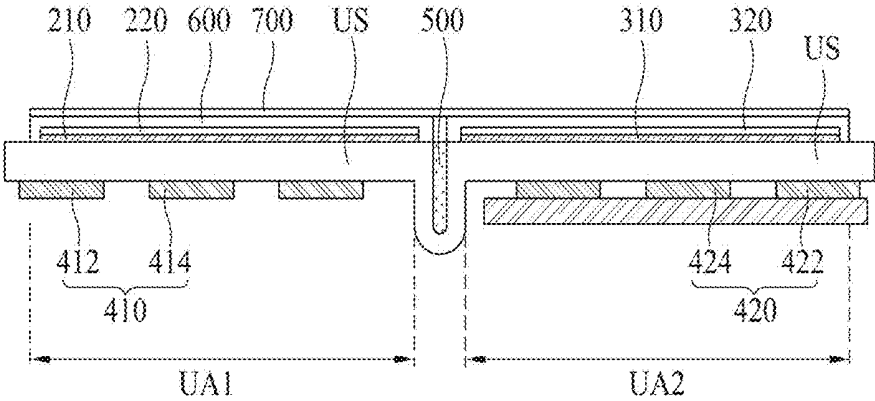

FIG. 11



FLEXIBLE DISPLAY DEVICE AND METHOD FOR FABRICATING THE SAME

CROSS REFERENCE TO RELATED APPLICATIONS

[0001] This application is a Continuation of U.S. patent application Ser. No. 14/983,876, filed Dec. 30, 2015, which claims the benefit of the Korean Patent Application No. 10-2015-0109144, filed on Jul. 31, 2015, both which are hereby incorporated by reference for all purposes as if fully set forth herein.

BACKGROUND

Technical Field

[0002] The present invention relates to a flexible display device.

Discussion of the Related Art

[0003] Examples of a display device used for a monitor of a computer, a TV, a cellular phone, etc., include an organic light emitting display (OLED), a plasma display panel (PDP), and a liquid crystal display (LCD). The OLED and the PDP emit light by themselves, while the LCD needs a separate light source.

[0004] Recently, a flexible display device fabricated of a flexible material, such as a plastic, has received attention as a next generation display device, and may display an image even in the example that the device is flexible like paper.

[0005] Such a flexible display device has various applications, ranging from personal portable device to monitors of a computer, TVs, and more, and a flexible display device that has a reduced volume and a reduced weight, while keeping a wide display area, has been studied.

[0006] Mass production of flexible display devices has been recently applied to small mobile products, TVs, etc., while manufacturers of display devices continue to study development of a more advanced type of display device using flexible properties.

SUMMARY

[0007] Accordingly, embodiments of the present invention are directed to a flexible display device and a method for fabricating the same, which substantially obviate one or more problems due to limitations and disadvantages of the related art.

[0008] An object of embodiments of the present invention is to provide a new type of flexible display device based on a property of a flexible substrate and a method for fabricating the same, and to provide a structure for reducing a bezel area where an image is not displayed and a method for fabricating the same.

[0009] To achieve these objects and other advantages and in accordance with the purpose of embodiments of the invention, as embodied and broadly described herein, a flexible display device comprises a flexible substrate including first and second portions that overlap each other, and a bending portion connecting the first portion with the second portion; a first display having a first organic light emitting diode on the first portion, the first display configured to display an image in a first direction; a second display having a second organic light emitting diode on the second portion, the second display configured to display an image in a

second direction; and a gate driver on the bending portion, the gate driver configured to drive gate lines in each of the first and second displays.

[0010] In another aspect, a method for fabricating a flexible display device comprises attaching a mother flexible substrate to a support substrate; forming a thin film transistor array on the mother flexible substrate to define a plurality of unit areas; forming an organic light emitting diode on the thin film transistor array; forming a unit flexible substrate by cutting the support substrate and the mother flexible substrate to include two unit areas adjacent to each other; connecting a driving circuit to each of the two unit areas; separating the support substrate from the unit flexible substrate; and bending the unit flexible substrate based on a center line between the two unit areas such that the two unit areas overlap with each other.

[0011] In another aspect, a flexible display device comprises a flexible substrate including a bending portion concavely bent along a center line, and first and second portions at opposite ends of the bending portion; a first display having a first organic light emitting diode on the first portion; and a second display having a second organic light emitting diode on the second portion.

[0012] In another aspect, a method for fabricating a flexible display device comprises attaching a mother flexible substrate to a support substrate; forming a thin film transistor array on the mother flexible substrate to define a plurality of unit areas; forming an organic light emitting diode on the thin film transistor array; forming a unit flexible substrate by cutting the support substrate and the mother flexible substrate to include two unit areas adjacent to each other; connecting a driving circuit to each of the two unit areas; separating the support substrate from the unit flexible substrate; and concavely bending the unit flexible substrate based on a center line between the two unit areas to allow one side of one of the two unit areas to be in contact with one side of the other one of the two unit areas.

[0013] It is to be understood that both the foregoing general description and the following detailed description of embodiments of the present invention are exemplary and explanatory and are intended to provide further explanation of the invention as claimed.

BRIEF DESCRIPTION OF THE DRAWINGS

[0014] The accompanying drawings, which are included to provide a further understanding of the invention and are incorporated in and constitute a part of this application, illustrate embodiments of the invention and together with the description serve to explain principles of the invention. In the drawings:

[0015] FIG. 1 is a cross-sectional view illustrating a flexible display device according to the first example embodiment of the present invention;

[0016] FIG. 2 is a plane view illustrating an example state before a substrate is bent in fabricating a flexible display device as shown in FIG. 1;

[0017] FIGS. 3A and 3B are flow charts of a method for fabricating a flexible display device according to the first example embodiment of the present invention;

[0018] FIG. 4 is a plane view illustrating a mother flexible substrate;

[0019] FIGS. 5A to 5H illustrate a method for fabricating a flexible display device according to the first example embodiment of the present invention;

[0020] FIG. 6 is a plane view illustrating a flexible display device according to the second example embodiment of the present invention;

[0021] FIG. 7 is a cross-sectional view illustrating a flexible display device as shown in FIG. 6;

[0022] FIG. 8 illustrates a 100 inch TV to which embodiments of the present invention are applied;

[0023] FIGS. 9A and 9B are flow charts of a method for fabricating a flexible display device according to the second example embodiment of the present invention;

[0024] FIGS. 10A to 10H illustrate a method for fabricating a flexible display device according to the second example embodiment of the present invention; and

[0025] FIG. 11 is a cross-sectional view illustrating a variation of the flexible display device shown in FIG. 6.

DETAILED DESCRIPTION

[0026] Terms disclosed in this specification should be understood as follows. The term of a singular expression should be understood to include a multiple expression as well as the singular expression if there is no specific definition in the context. The terms such as “the first” and “the second” are used only to differentiate one element from other elements. Thus, a scope of claims is not limited by these terms. Also, it should be understood that the term such as “include” or “have” does not preclude existence or possibility of one or more features, numbers, steps, operations, elements, parts or their combinations. It should be understood that the term “at least one” includes all combinations related with any one item. For example, “at least one among a first element, a second element and a third element” may include all combinations of two or more elements selected from the first, second and third elements as well as each element of the first, second and third elements. Also, if it is mentioned that a first element is positioned “on or above” a second element, it should be understood that the first and second elements may be brought into contact with each other, or a third element may be interposed between the first and second elements.

[0027] Hereinafter, example embodiments of a flexible display device and a method for fabricating the same according to the present invention will be described with reference to the accompanying drawings.

[0028] FIG. 1 is a cross-sectional view illustrating a flexible display device according to the first example embodiment of the present invention. FIG. 2 is a plane view illustrating a state before a substrate is bent in fabricating a flexible display device shown in FIG. 1.

[0029] With reference to FIG. 1, the flexible display device according to the first example embodiment includes a flexible substrate 100, first and second display units 200 and 300 arranged on the flexible substrate 100, and a driving circuit 400 connected to one side of the flexible substrate 100.

[0030] The flexible substrate 100 has a bending property. To this end, plastic, which includes polyethylene naphthalate, polyethylene terephthalate, polycarbonate and polyethersulfone, and a metal foil, which includes Stainless Steel (SUS), may be used as materials of the flexible substrate 100.

[0031] One side of the flexible substrate 100 is bent. In more detail, as shown in FIG. 2, the flexible substrate 100 is bent based on its center line CL. That is, the flexible substrate 100 according to the first example embodiment is

formed such that the first and second display units 200 and 300 are formed on the flexible substrate 100, which is flat, and then the flexible substrate 100 is bent.

[0032] Therefore, the flexible substrate 100 includes a first portion 110, a second portion 120, and a bending portion 130, wherein the first portion 110 and the second portion 120 overlap with each other when the flexible substrate 100 is bent. The first portion 110 and the second portion 120 have the same shapes and areas as each other. One side of the first portion 110 is connected to one side of the second portion 120 by the bending portion 130.

[0033] In this example, the bending portion 130 of the flexible substrate 100 is fixed with a specific curvature. To this end, a support member 500 for supporting and fixing the flexible substrate 100 is disposed on the bending portion 130.

[0034] A cross-section of the support member 500 includes a flat surface and a curved surface convexedly extended from the flat surface to one side, and having a specific curvature. The curved surface of the support member 500 is arranged toward the center line CL of the flexible substrate 100. In this example, the center line CL is disposed at the bending portion 130 of the flexible substrate 100.

[0035] The first display unit 200 is disposed on the first portion 110 of the flexible substrate 100. The first display unit 200 includes a first organic light emitting diode 220 displaying an image in a first direction.

[0036] In more detail, the first display unit 200 may include a thin film transistor array 210 disposed on the first portion 110 of the flexible substrate 100, a first organic light emitting diode 220 deposited on the thin film transistor array 210, and an encapsulation layer 600 covering the first organic light emitting diode 220.

[0037] The first direction may be an upward direction of the flexible substrate 100. Therefore, the first organic light emitting diode 220 displays an image in an upward direction of the flexible substrate 100.

[0038] The second display unit 300 is disposed on the second portion 120 of the flexible substrate 100. The second display unit 300 includes a second organic light emitting diode 320 displaying an image in a second direction.

[0039] In more detail, the second display unit 300 may include a thin film transistor array 310 disposed on the second portion 120 of the flexible substrate 100, a second organic light emitting diode 320 deposited on the thin film transistor array 310, and an encapsulation layer 600 covering the second organic light emitting diode 320. In this example, the second organic light emitting diode 320 displays an image in a second direction.

[0040] The second direction may be a downward direction of the flexible substrate 100. Therefore, the second organic light emitting diode 320 displays an image in a downward direction of the flexible substrate 100.

[0041] As described above, in the flexible display device according to the first example embodiment of the present invention, one side of the flexible substrate 100 is bent. The organic light emitting diodes 220 and 320 are respectively arranged on the first portion 110 and the second portion 120 of the flexible substrate 100, which overlap each other, whereby a dual display device displaying an image in dual directions is realized.

[0042] In an example, the first and second organic light emitting diodes 220 and 320 include a structure of an anode

electrode, a hole injection layer, an organic light emitting layer, an electron injection layer, and a cathode electrode, deposited in due order.

[0043] Emission principles of the first and second organic light emitting diodes **220** and **320** will briefly be described as follows. If electrons generated from the cathode electrode and holes generated from the anode electrode are injected into the light emitting layer, excitons are generated by a combination of the injected electrons and holes. Then, the excitons are transitioned from an excited state to a ground state to emit light, whereby an image is displayed.

[0044] As shown in FIG. 1, a polarizing film **700** for improving an ambient contrast ratio (ACR) may be provided on the uppermost layers of the first and second display units **200** and **300**.

[0045] The driving circuit **400** includes a first driving circuit **410** connected to the first portion **110** of the flexible substrate **100** and a second driving circuit **420** connected to the second portion **120** of the flexible substrate **100**.

[0046] The first driving circuit **410** includes a printed circuit board **414** provided at one side of the flexible substrate **100** and a plurality of circuit films **412** connecting the printed circuit board **414** with the flexible substrate **100**.

[0047] The printed circuit board **414** is provided with a control circuit, which is not shown, and a driving voltage generating circuit. In this example, the printed circuit board **414** may be a flexible printed circuit board (FPCB).

[0048] The plurality of circuit films **412** may be chip on films (COF), each of which may be provided with a data drive integrated circuit (IC) **430** packaged therein.

[0049] The printed circuit board **414** and the plurality of circuit films **412** are folded with respect to a rear surface of the flexible substrate **100** and then arranged between the first portion **110** and the second portion **120** of the flexible substrate **100** as the flexible substrate **100** is bent.

[0050] The second driving circuit **420** includes elements substantially the same as those of the first driving circuit **410**. That is, the second driving circuit **420** includes a printed circuit board **424** provided at one side of the flexible substrate **100** and a plurality of circuit films **422** connecting the printed circuit board **424** with the flexible substrate **100**.

[0051] Meanwhile, the first driving circuit **410** further includes a first gate driver **230** for driving a plurality of gate lines provided in the first display unit **200**. The first gate driver **230** is provided at one side of the first display unit **200**.

[0052] Also, the second driving circuit **420** further includes a second gate driver **240** for driving a plurality of gate lines provided in the second display unit **300**. The second gate driver **240** is provided at one side of the second display unit **300**.

[0053] The first and second gate drivers **230** and **240** are disposed between the first display unit **200** and the second display unit **300**. Therefore, a plurality of gate signal transmission lines TL2 for transmitting a plurality of first and second gate control signals provided respectively from the first and second driving circuits **410** and **420** to each of the first and second gate drivers **230** and **240** are arranged between the first display unit **200** and the second display unit **300**.

[0054] In the first example embodiment, the gate drivers and the gate signal transmission lines TL2 for transmitting the plurality of gate control signals to the gate drivers are arranged in the bending portion **130**. According to example

embodiments of the present invention, the gate drivers **230** and **240** and the plurality of gate signal transmission lines TL2 are not arranged in an outer bezel area of each of the first and second display units **200** and **300**, whereby a width of the outer bezel area may be reduced.

[0055] Meanwhile, in the first example embodiment, as the plurality of gate signal transmission lines TL2 are arranged in the bending portion **130**, a structure for the plurality of gate signals to be transferred from the printed circuit board **414** to the flexible substrate **100** is varied. This will be described in more detail as follows.

[0056] Generally, the circuit films **412** may package the data drive IC **430** therein to drive the data lines arranged in the display unit. Some of the plurality of circuit films **412** transfer gate control signals and a driving voltage, provided from the printed circuit board **414**, to the flexible substrate **100**.

[0057] To this end, in the display device of the related art, a transfer line TL1 for transferring gate control signals and a driving voltage provided from the printed circuit board **414** to the flexible substrate **100** may be provided in the outermost circuit film **412** among the plurality of circuit films **412**. This is because a gate driver is provided at one side of the flexible substrate **100**.

[0058] On the other hand, in the first example embodiment, because the gate driver is arranged along the bending portion **130** of the flexible substrate **100**, that is, the center line CL, the transfer line TL1 is arranged in the circuit film **412** arranged at the center among the plurality of circuit films **412**. For example, with reference to the example shown in FIG. 2, if six circuit films **412** are provided, the transfer line TL1 is arranged at the third and fourth circuit films **412**.

[0059] Hereinafter, a method for fabricating the aforementioned flexible display device according to the first example embodiment of the present invention will be described in detail.

[0060] FIGS. 3A and 3B are flow charts of a method for fabricating a flexible display device according to the first example embodiment of the present invention. FIG. 4 is a plane view illustrating a mother flexible substrate MS. FIGS. 5A to 5H illustrate a method for fabricating a flexible display device according to the first example embodiment of the present invention.

[0061] With reference to FIGS. 3A and 3B, the method for fabricating the flexible display device according to the first example embodiment includes a step (first process) S10 of attaching the mother flexible substrate MS to the support substrate **1000**, a step (second process) S20 of forming the thin film transistor array **210** on the mother flexible substrate MS, a step (third process) S30 of forming an organic light emitting diode on the thin film transistor array **210**, a step (fourth process) S40 of cutting the mother flexible substrate MS, a module step (fifth process) S50 of connecting the driving circuit **400** to a unit area UA formed by cutting of the mother flexible substrate MS, a step (sixth process) S60 of separating the support substrate **1000** from the mother flexible substrate MS, and a step (sixth process) S70 of attaching the polarizing film **700** to each unit area UA.

[0062] In the first example embodiment, the method further includes a step (eighth process) S80 of bending the mother flexible substrate MS after cutting the mother flex-

ible substrate MS. The eighth process S80 may be performed before or after the step of attaching the polarizing film 700 to each unit area UA.

[0063] With reference to FIG. 5A, the first process S10 is to attach the mother flexible substrate MS to the support substrate 1000 to facilitate handling of the mother flexible substrate MS during the processes. The support substrate 1000 is attached to the rear surface of the flexible substrate 100 such that the mother flexible substrate MS is neither easily bent nor distorted during a later process. To this end, a glass substrate thicker than the mother flexible substrate MS may be used as the support substrate 1000.

[0064] The mother flexible substrate MS is divided into a plurality of unit areas UA. Each of the plurality of unit areas UA corresponds to a single unit display device. In the drawing, one mother flexible substrate MS is configured to generate six unit display devices. However, the number of unit display devices that may be generated by one mother flexible substrate MS is not limited to the examples shown and described herein.

[0065] With reference to FIG. 5B, the second process S20 is to form the thin film transistor array 210 after the first process S10. The thin film transistor array 210 is formed per the plurality of unit areas UA. The thin film transistor array 210 includes gate lines, data lines crossing the gate lines, a plurality of signal transmission lines, a plurality of pad electrodes, and a thin film transistor connected to the gate and data lines.

[0066] The second process S20 includes the step of forming a gate driver and a plurality of gate signal lines TL2 connected to the gate driver between neighboring unit areas UA adjacent to each other. In this example, the gate driver includes first and second gate drivers 230 and 240 arranged to be adjacent to each other. The first gate driver 230 is connected to the first unit area UA of the neighboring unit areas, which is arranged at one side, and the second gate driver 240 is connected to the second unit area UA of the neighboring unit areas, which is arranged at the other side.

[0067] With reference to FIG. 5C, the third process S30 is to form the organic light emitting diode after the second process S20. The organic light emitting diode is formed for each of the plurality of unit areas UA. The organic light emitting diode is divided into the first light emitting device 220 and the second light emitting device 320 during a later process. In more detail, in the later fourth process S40, the mother flexible substrate MS is cut on a basis of two unit areas UA, whereby the organic light emitting diode is divided into the first organic light emitting diode 220 and the second organic light emitting diode 320, which are arranged respectively in two unit areas UA.

[0068] With reference to FIG. 5D, the fourth process S40 is to cut the mother flexible substrate MS on a basis of two unit areas UA after the third process S30. In more detail, the fourth process S40 is to cut the mother flexible substrate MS on a basis of the outside of the unit area UA, in accordance with the intended use of the display, and/or design specifications. The method for fabricating the flexible display device according to the first example embodiment may facilitate realization of a dual display device by cutting two unit areas UA at a time, and thereby improve process throughput.

[0069] Hereinafter, for convenience of description, each mother flexible substrate MS separated by cutting two unit areas UA during the fourth process S40 will be termed a

“unit flexible substrate US.” For example, in FIG. 4, one mother flexible substrate MS is configured to generate six unit display devices. In this example, the one mother flexible substrate MS is cut to generate three unit flexible substrates US. For reference, the flexible substrate 100 shown in FIGS. 1 and 2 represents one unit flexible substrate US.

[0070] With reference to FIG. 5E, the fifth process S50 is to connect the driving circuit 400 after the fourth process S40. In more detail, the fifth process S50 is to connect the driving circuit 400 to a plurality of pads formed on the unit flexible substrate US during the second process S20. At this time, the circuit films 412 of the driving circuit 400 are connected to the plurality of pads in a type of tape automated bonding (TAB). Therefore, each unit area UA is connected to the printed circuit board 414 through the circuit films 412.

[0071] With reference to FIG. 5F, the sixth process S60 is to separate the support substrate 1000 from the unit flexible substrate US. The unit flexible substrate US has flexibility after the sixth process S60.

[0072] With reference to FIG. 5G, the seventh process S70 is to attach the polarizing film 700 to each unit area UA. The polarizing film 700 is attached to an encapsulation substrate 600, which encapsulates the first and second organic light emitting diodes 220 and 320, and serves to improve an ambient contrast ratio (ACR).

[0073] With reference to FIG. 5H, the eighth process S80 is to bend the unit flexible substrate US. In more detail, the eighth process S80 is to superimpose two unit areas UA on each other by bending the unit flexible substrate US based on the center line CL arranged between the two unit areas UA. In this eighth process S80, the printed circuit board 414 and the plurality of circuit films 412 are folded toward the rear surface of the flexible substrate 100. That is, the printed circuit board 414 and the plurality of circuit films 412 are arranged between the first portion 110 and the second portion 120 of the unit flexible substrate US as the unit flexible substrate US is bent.

[0074] FIG. 6 is a plane view illustrating a flexible display device according to a second example embodiment of the present invention. FIG. 7 is a cross-sectional view illustrating a flexible display device shown in FIG. 6. FIG. 8 illustrates a 100 inch TV to which embodiments of the present invention are applied.

[0075] With reference to FIG. 6, the flexible display device according to the second example embodiment includes a flexible substrate 100, first and second display units 200 and 300 disposed on the flexible substrate 100, and a driving circuit 400 connected to one side of the flexible substrate 100.

[0076] The flexible substrate 100 has a bending property. To this end, plastic, which includes polyethylene naphthalate, polyethylene terephthalate, polycarbonate and polyethersulfone, and a metal foil, which includes stainless steel (SUS), may be used as materials of the flexible substrate 100.

[0077] A center area of the flexible substrate 100 is bent. In more detail, as shown in FIG. 6, the flexible substrate 100 has a bending portion 130 concavely bent based on its center line CL.

[0078] Therefore, the flexible substrate 100 includes a first portion 110, a second portion 120, and a bending portion 130 arranged between the first and second portions 110 and 120, wherein the first portion 110 and the second portion 120 have the same height as each other. That is, the bending

portion **130** is formed along the center line CL, and the first and second portions **110** and **120** are arranged at both sides of the bending portion **130**. The first and second portions **110** and **120** may have the same shape and the same area as each other.

[0079] In the second example embodiment, as the bending portion **130** is formed along the center line CL, an interval between the display units provided in each of the first and second portions **110** and **120** may be reduced.

[0080] In this example, the bending portion **130** of the flexible substrate **100** is fixed with a specific curvature. To this end, a support member **500** for supporting and fixing the flexible substrate **100** is disposed on the bending portion **130**.

[0081] A cross-section of the support member **500** includes a flat surface having the same height as those of the first and second portions **110** and **120** and a curved surface concavely extended from the flat surface to a lower side, and having a specific curvature. The curved surface of the support member **500** is arranged toward a rear surface of the flexible substrate **100**.

[0082] The first display unit **200** is disposed on the first portion **110** of the flexible substrate **100**. In more detail, the first display unit **200** may include a thin film transistor array **210** disposed on the first portion **110** of the flexible substrate **100**, a first organic light emitting diode **220** deposited on the thin film transistor array **210**, and an encapsulation layer **600** covering the first organic light emitting diode **220**.

[0083] The second display unit **300** is disposed on the second portion **120** of the flexible substrate **100**. In more detail, the second display unit **300** may include a thin film transistor array **310** disposed on the second portion **120** of the flexible substrate **100**, a second organic light emitting diode **320** deposited on the thin film transistor array **310**, and an encapsulation layer **600** covering the second organic light emitting diode **320**.

[0084] As described above, in the flexible display device according to the second example embodiment of the present invention, the center area of the flexible substrate **100** is bent concavely. In example embodiments of the present invention as above, the first and second display units **200** and **300**, which may be driven independently from each other, are connected with each other, whereby a multi-vision display device may be realized. A width of a non-display area disposed between the first and second display units **200** and **300** is reduced by the bending portion **130**, whereby a seam area between the first and second display units **200** and **300** may be realized to be close to or about zero.

[0085] Therefore, in embodiments of the present invention, two independent unit display devices may be connected to each other, and at the same time, a zero or about zero seam may be realized, whereby a large scale display device may easily be realized. For example, 100 inch TVs, as mass-produced by manufacturers of display devices, have been expensive products up to now, but their manufacture may be facilitated and their manufacturing cost may be reduced if two 55 inch display panels are connected to each other, as shown in FIG. **8** and in accordance with embodiments of the present invention.

[0086] According to embodiments of the present invention, because the first and second display units **200** and **300**, which are independent from each other, are connected to each other, a large scale TV may be realized. For this reason, 120 Hz driving, which may be difficult to realize in con-

ventional 100 inch-TVs due to RC delay, may be more easily realized. Images of higher quality may therefore be provided.

[0087] For reference, the 120 Hz driving technique may provide images of high quality by providing images of 120 frames per 1 second. The 120 Hz driving technique may be applied to a 55 inch display device. However, due to RC delay in the signal lines, it has been difficult to realize the 120 Hz driving technique in a large scale display screen. For this reason, the 120 Hz driving technique has typically not been applied to display devices of more than 55 inches.

[0088] With reference to the first and second organic light emitting diodes **220** and **320** of the second example embodiment, these diodes include a structure of an anode electrode, a hole injection layer, an organic light emitting layer, an electron injection layer, and a cathode electrode, deposited in due order.

[0089] Emission principles of the first and second organic light emitting diodes **220** and **320** are similar to those of the first example embodiment, but will briefly be described as follows. If electrons generated from the cathode electrode and holes generated from the anode electrode are injected into the light emitting layer, excitons are generated by combination of the injected electrons and holes. Then, the excitons are transitioned from an excited state to a ground state to emit light, whereby an image is displayed.

[0090] As shown in FIG. **7**, a polarizing film **700** for improving an ambient contrast ratio (ACR) may be provided on the uppermost layers of the first and second display units **200** and **300**.

[0091] The driving circuit **400** includes a first driving circuit **410** connected to the first portion **110** of the flexible substrate **100** and a second driving circuit **420** connected to the second portion **120** of the flexible substrate **100**.

[0092] The first driving circuit **410** includes a printed circuit board **414** provided at one side of the flexible substrate **100**, and a plurality of circuit films **412** connecting the printed circuit board **414** with the flexible substrate **100**.

[0093] The printed circuit board **414** is provided with a control circuit, which is not shown, and a driving voltage generating circuit. In this example, the printed circuit board **414** may be a flexible printed circuit board (FPCB).

[0094] The plurality of circuit films **412** may be chip on films (COF), each of which may be packaged with a data drive integrated circuit (IC) **430** therein.

[0095] The second driving circuit **420** includes elements substantially the same as those of the first driving circuit **410**. That is, the second driving circuit **420** includes a printed circuit board **424** provided at one side of the flexible substrate **100**, and a plurality of circuit films **422** connecting the printed circuit board **424** with the flexible substrate **100**.

[0096] Meanwhile, the first driving circuit **410** further includes a first gate driver **230** for driving a plurality of gate lines provided in the first display unit **200**. The first gate driver **230** is provided at one side of the first display unit **200**. Also, the second driving circuit **420** further includes a second gate driver **240** for driving a plurality of gate lines provided in the second display unit **300**. The second gate driver **240** is provided at one side of the second display unit **300**.

[0097] The first and second gate drivers **230** and **240** are disposed between the first display unit **200** and the second display unit **300**. Therefore, a plurality of gate signal transmission lines TL2 for transmitting a plurality of first and

second gate control signals provided from the first and second driving circuits **410** and **420** to each of the first and second gate drivers **230** and **240** are arranged between the first display unit **200** and the second display unit **300**.

[0098] In the second example embodiment, the gate drivers and the gate signal transmission lines TL2 for transmitting the plurality of gate control signals to the gate drivers are arranged in the bending portion **130**. According to example embodiments of the present invention, the gate drivers **230** and **240** and the plurality of gate signal transmission lines TL2 are not arranged in an outer bezel area of each of the first and second display units **200** and **300**, whereby a width of the outer bezel area may be reduced.

[0099] Hereinafter, a method for fabricating the aforementioned flexible display device according to the second example embodiment of the present invention will be described in detail.

[0100] FIGS. 9A and 9B are flow charts of a method for fabricating a flexible display device according to the second example embodiment of the present invention. FIGS. 10A to 10H illustrate a method for fabricating a flexible display device according to the second example embodiment of the present invention.

[0101] With reference to FIGS. 9A and 9B, a method for fabricating the flexible display device according to the second example embodiment includes a step (first process) S10 of attaching a mother flexible substrate MS to a support substrate **1000**, a step (second process) S20 of forming the thin film transistor array **210** on the mother flexible substrate MS, a step (third process) S30 of forming an organic light emitting diode on the thin film transistor array **210**, a step (fourth process) S40 of cutting the mother flexible substrate MS, a module step (fifth process) S50 of connecting the driving circuit **400** to a unit area UA formed by cutting of the mother flexible substrate MS, a step (sixth process) S60 of separating the support substrate **1000** from the mother flexible substrate MS, and a step (sixth process) S70 of attaching the polarizing film **700** to each unit area UA.

[0102] In the second example embodiment, the method further includes a step (eighth process) S80 of bending the mother flexible substrate MS after cutting the mother flexible substrate MS. The eighth process S80 may be performed before or after the step of attaching the polarizing film **700** to each unit area UA.

[0103] With reference to FIG. 10A, the first process S10 is to attach the mother flexible substrate MS to the support substrate **1000** to facilitate handling of the mother flexible substrate MS during the processes. The support substrate **1000** is attached to the rear surface of the flexible substrate **100** such that the mother flexible substrate MS is neither bent nor distorted during a later process. To this end, a glass substrate thicker than the mother flexible substrate MS may be used as the support substrate **1000**.

[0104] The mother flexible substrate MS is divided into a plurality of unit areas UA. Each of the plurality of unit areas UA corresponds to a single unit display device.

[0105] With reference to FIG. 10B, the second process S20 is to form the thin film transistor array **210** after the first process S10. The thin film transistor array **210** is formed per the plurality of unit areas UA. The thin film transistor array **210** includes gate lines, data lines crossing the gate lines, a plurality of signal transmission lines, a plurality of pad electrodes, and a thin film transistor connected to the gate and data lines.

[0106] The second process S20 includes the step of forming a gate driver and a plurality of gate signal lines TL2, which are connected to the gate driver, between neighboring unit areas UA adjacent to each other. In this example, the gate driver includes first and second gate drivers **230** and **240** arranged to be adjacent to each other. The first gate driver **230** is connected to the first unit area UA of the neighboring unit areas, which is arranged at one side, and the second gate driver **240** is connected to the second unit area UA of the neighboring unit areas, which is arranged at the other side.

[0107] With reference to FIG. 10C, the third process S30 is to form the organic light emitting diode after the second process S20. The organic light emitting diode is formed for each of the plurality of unit areas UA. The organic light emitting diode is divided into the first light emitting device **220** and the second light emitting device **320** during a later process. In more detail, in the later fourth process S40, the mother flexible substrate MS is cut on a basis of two unit areas UA, whereby the organic light emitting diode is divided into the first organic light emitting diode **220** and the second organic light emitting diode **320**, which are arranged respectively in two unit areas UA.

[0108] With reference to FIG. 10D, the fourth process S40 is to cut the mother flexible substrate MS on a basis of two unit areas UA after the third process S30. In more detail, the fourth process S40 is to cut the mother flexible substrate MS on a basis of the outside of the unit area UA in accordance with the intended use of the display and/or design specifications. The method for fabricating the flexible display device according to the second example embodiment may facilitate realization of a multi-vision display device by cutting two unit areas UA at a time, and thereby improve process throughput.

[0109] Hereinafter, for convenience of description, each mother flexible substrate MS separated by cutting two unit areas UA during the fourth process S40 will be termed a "unit flexible substrate US".

[0110] With reference to FIG. 10E, the fifth process S50 is to connect the driving circuit **400** after the fourth process S40. In more detail, the fifth process S50 is to connect the driving circuit **400** to a plurality of pads formed on the unit flexible substrate US during the second process S20. At this time, the circuit films **412** of the driving circuit **400** are connected to the plurality of pads in a type of tape automated bonding (TAB). Therefore, each unit area UA is connected to the printed circuit board **414** through the circuit films **412**.

[0111] With reference to FIG. 10F, the sixth process S60 is to separate the support substrate **1000** from the unit flexible substrate US. The unit flexible substrate US has flexibility by means of the sixth process S60.

[0112] With reference to FIG. 10G, the seventh process S70 is to attach the polarizing film **700** to each unit area UA. The polarizing film **700** is attached to an encapsulation substrate **600**, which encapsulates the first and second organic light emitting diodes **220** and **320**, and serves to improve an ambient contrast ratio (ACR).

[0113] With reference to FIG. 10H, the eighth process S80 is to bend the unit flexible substrate US. In more detail, the eighth process S80 is to concavely bend the center area of the flexible substrate **100** based on the center line CL arranged between the two unit areas UA. In this eighth

process **S80**, the printed circuit board **414** and the plurality of circuit films **412** are folded toward the rear surface of the flexible substrate **100**.

[0114] Meanwhile, the eighth process **S80** may use the support member **500** to bend the unit flexible substrate **US**. In more detail, the eighth process **S80** may include the steps of arranging the support member **500** to correspond to the center line **CL** of the unit flexible substrate **US**, and concavely bending a part of the unit flexible substrate **US** while surrounding a surface of the support member **500**.

[0115] In this example, a cross-section of the support member **500** includes a flat surface and a curved surface concavely extended from the flat surface to one side, and having a specific curvature. Therefore, one sides of the two unit areas **UA** are in contact with each other by interposing the flat surface of the support member **500** therebetween.

[0116] FIG. 11 illustrates a variation of the second example embodiment. In FIG. 11, the polarizing film **700** is disposed across both of the unit areas **UA1** and **UA2**, including above the support member **500**. In this way, a seam between the unit areas **UA1** and **UA2** may be less noticeable.

[0117] As described above, in the flexible display device according to embodiments of the present invention, one side of the flexible substrate **100** is bent, and the organic light emitting diodes **220** and **320** are respectively arranged above the first portion **110** and the second portion **120** of the flexible substrate **100**, which are superimposed on each other, whereby a dual display device displaying an image in a dual direction is realized. According to embodiments of the present invention, the gate drivers and the gate signal transmission lines **TL2** for transmitting the plurality of gate control signals to the gate drivers are arranged in the bending portion **130** between the first and second portions **110** and **120**, whereby the width of the outer bezel area may be reduced.

[0118] Also, the method for fabricating the flexible display device according to embodiments of the present invention may facilitate realization of the dual display device by cutting two unit areas **UA** at a time, and thereby improve process throughput.

[0119] Also, in the flexible display device according to embodiments of the present invention, the first and second display units **200** and **300**, which may be driven independently from each other, are connected with each other, whereby the multi-vision display device may be provided. As the bending portion arranged **130** between the first and second display units **200** and **300** is bent concavely, the width of the non-display area may be reduced, and the seam area between the first and second display units **200** and **300** may be realized to be close to or about zero. Therefore, in embodiments of the present invention, a large scale TV, such as a 100 inch-TV, may easily be fabricated, and its fabricating cost may be reduced.

[0120] Also, in embodiments of the present invention, because the first and second display units **200** and **300**, which are independent from each other, may be connected to each other, a large scale TV may be realized. Therefore, 120 Hz driving, which is difficult to realize in the conventional large-scale display device due to RC delay, may herein be realized more easily, whereby images of high quality may be provided.

[0121] Also, methods for fabricating the flexible display device according to example embodiments of the present

invention may facilitate realization of the multi-vision display device by cutting two unit areas **UA** at a time, and thereby improve process throughput.

[0122] It will be apparent to those skilled in the art that various modifications and variations can be made in the present invention without departing from the spirit or scope of the inventions. Thus, it is intended that the present invention covers the modifications and variations of this invention provided they come within the scope of the appended claims and their equivalents.

What is claimed is:

1. A flexible display device, comprising:
 - a flexible substrate including:
 - first and second portions that overlap each other, and
 - a bending portion connecting the first portion with the second portion;
 - a first display having a first organic light emitting diode on the first portion;
 - a second display having a second organic light emitting diode on the second portion;
 - a first gate driver on the bending portion, the first gate driver configured to drive gate lines in the first display; and
 - a second gate driver on the bending portion, the second gate driver configured to drive gate lines in the second display,
 - wherein the first gate driver and the second gate driver are provided in the bending portion between the first display and the second display, and are connected to a first and second driving circuit respectively.
2. The flexible display device of claim 1, wherein the flexible substrate is bent based on a center line in the bending portion.
3. The flexible display device of claim 2, wherein the center line in the bending portion is provided between the first gate driver and the second gate driver.
4. The flexible display device of claim 2, wherein the first gate driver and the second gate driver are provided along with the center line in the bending portion.
5. The flexible display device of claim 1, wherein the flexible substrate has a first and second side,
 - the first and second portions are provided along with the first side,
 - the bending portion is provided along with the second side, and
 - the first side is longer than the second side in the flexible substrate.
6. The flexible display device of claim 1, wherein the first and second portions have the same shape and area as each other.
7. The flexible display device of claim 1, wherein the first driving circuit is connected to one side of the first portion, the first driving circuit is configured to supply a plurality of first driving signals to the first display and the first gate driver,
 - the second driving circuit is connected to one side of the second portion, and
 - the second driving circuit is configured to supply a plurality of second driving signals to the second display and the second gate driver.
8. The flexible display device of claim 7, wherein a gap between the first driving circuit and the second driving circuit facing the first driving circuit is smaller than a gap between the first display and the second display.

9. The flexible display device of claim 7, wherein a plurality of gate signal transmission lines for transmitting a plurality of gate control signals from the first and second driving circuits to the gate drivers are in the bending portion.

10. The flexible display device of claim 7, wherein the first driving circuit includes a printed circuit board and a plurality of circuit films, and

the second driving circuit includes a printed circuit board and a plurality of circuit films.

11. The flexible display device of claim 10, wherein a plurality of gate signal transmission lines for transmitting a plurality of gate control signals from the printed circuit board of the first driving circuit to the first gate driver is provided on one of the plurality of circuit films of the first driving circuit,

a plurality of gate signal transmission lines for transmitting a plurality of gate control signals from the printed circuit board of the second driving circuit to the second gate driver is provided on one of the plurality of circuit films of the second driving circuit, and

the one of the plurality of circuit film of the first driving circuit and the one of the plurality of circuit film of the second driving circuit are respectively provided in a region adjacent to a center line in the bending portion.

12. The flexible display device of claim 11, wherein each of the plurality of gate signal transmission lines has at least one curved portion.

13. The flexible display device of claim 12, wherein the plurality of gate signal transmission lines provided on the first portion and the plurality of gate signal transmission lines provided on the second portion are formed to be symmetric with respect to the center line.

14. The flexible display device of claim 1, wherein a size of the first display and a size of the second display is same or different.

15. The flexible display device of claim 1, wherein the first display includes:

a thin film transistor array disposed on the first portion;
a first organic light emitting diode deposited on the thin film transistor array; and
and an encapsulation layer covering the first organic light emitting diode, and

the second display includes:

a thin film transistor array disposed on the second portion;
a second organic light emitting diode deposited on the thin film transistor array; and
an encapsulation layer covering the second organic light emitting diode.

16. The flexible display device of claim 15, wherein the encapsulation layer of the first display covers the first gate driver, and the encapsulation layer of the second display covers the second gate driver.

17. The flexible display device of claim 15, wherein a polarizing film is provided on at least one of the encapsulation layers of the first and second displays.

18. The flexible display device of claim 7, wherein the first display and the second display are provided on a first surface of the flexible substrate,

the first driving circuit and the second driving circuit are provided on a second surface of the flexible substrate, the first surface and the second surface being opposite to each other, and

when the first portion and the second portion overlaps each other, the first driving circuit and the second driving circuit are provided to face each other.

19. The flexible display device of claim 7, wherein the first gate driver and the second gate driver is provided on a first surface of the flexible substrate,

the first driving circuit and the second driving circuit are provided on a second surface of the flexible substrate, and

the first surface and the second surface are opposite to each other.

20. The flexible display device of claim 10, wherein one of the plurality of circuit film of the first driving circuit connected to a plurality of gate signal transmission lines is provided in a region adjacent to a center line in the bending portion, and

one of the plurality of circuit film of the second driving circuit connected to a plurality of gate signal transmission lines is provided in a region adjacent to a center line in the bending portion.

* * * * *

专利名称(译)	柔性显示装置及其制造方法		
公开(公告)号	US20180366059A1	公开(公告)日	2018-12-20
申请号	US16/110943	申请日	2018-08-23
[标]申请(专利权)人(译)	乐金显示有限公司		
申请(专利权)人(译)	LG DISPLAY CO. , LTD.		
当前申请(专利权)人(译)	LG DISPLAY CO. , LTD.		
[标]发明人	LEE CHANWOO MIN SUNGJOON LEE KWONHYUNG OH YEONJUN		
发明人	LEE, CHANWOO MIN, SUNGJOON LEE, KWONHYUNG OH, YEONJUN		
IPC分类号	G09G3/3225 H01L27/32 G09G5/00 H01L51/00 G06F3/038		
CPC分类号	H01L2251/566 G09G2310/0221 H01L27/3267 G09G2310/0283 H01L2251/5338 G06F3/038 H01L51/003 Y02E10/549 G09G2380/02 G09G3/3225 G09G5/00 H01L51/0097 G09F9/301 G09F9/33		
优先权	1020150109144 2015-07-31 KR		
其他公开文献	US10217406		
外部链接	Espacenet USPTO		

摘要(译)

一种柔性显示装置，包括：柔性基板，包括彼此重叠的第一和第二部分；以及弯曲部分，连接第一部分和第二部分。具有第一有机发光二极管的第一显示器位于第一部分上，第一显示器配置为沿第一方向显示图像，具有第二有机发光二极管的第二显示器位于第二部分上，第二显示器配置为以第二方向显示图像。栅极驱动器位于弯曲部分上，并且被配置为驱动第一和第二显示器中的每一个中的栅极线。

